

LED Inground Lamp



HIGH QUALITY LED LIGHT SOURCE

- Energy Efficient
- High Brightness
- Long Life Span

IP67 RATING

- Protection Against Water Immersion
- Completely Protected Against Dust

STAINLESS STEEL FACE

- Anti-Corrosion
- Anti-Aging Finish

APPLICATIONS

- In Concrete
- Drive Ways
- Stairs

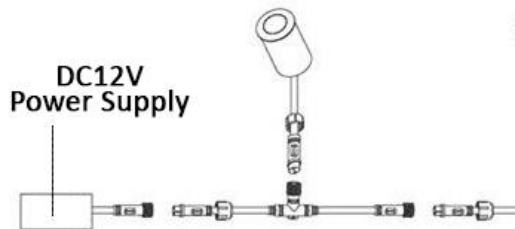

DIMENSIONS

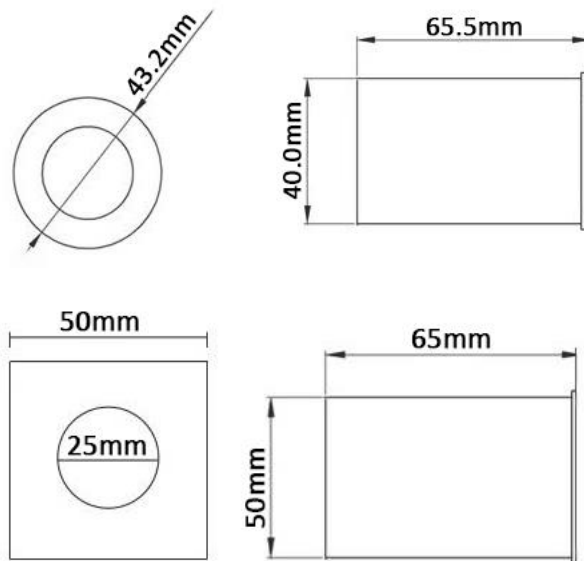

SPECIFICATIONS

| ROUND INGROUND | | | | | | | | |
|-----------------|---------------|----------|-----------|--------------------|---------|--------------------|-----------------------|------------|
| Model | Color | LED Type | CCT (K) | Max Current (Amps) | Voltage | Luminous Flux (lm) | Dimensions (DxWxH mm) | Beam Angle |
| INGROUND-W | White | 2 Watt | 5000-7000 | 1.2 | 12VDC | 140 | 43.2x65.5 | 45/60/90° |
| INGROUND-WW | Warm White | | 2700-3500 | | | 155 | | |
| INGROUND-NW | Natural White | | 4000-5000 | | | 160 | | |
| SQUARE INGROUND | | | | | | | | |
| Model | Color | LED Type | CCT (K) | Max Current (Amps) | Voltage | Luminous Flux (lm) | Dimensions (DxWxH mm) | Beam Angle |
| INGROUND-W | White | 2 Watt | 5000-7000 | 1.2 | 12VDC | 140 | 50x50x65 | 45/60/90° |
| INGROUND-WW | Warm White | | 2700-3500 | | | 155 | | |
| INGROUND-NW | Natural White | | 4000-5000 | | | 160 | | |